

“Bella,” my mom said to me — the last of a thousand times — before I got on the plane. “You don’t have to do this.”

My mom looks like me, except with short hair and laugh lines. I felt a spasm of panic as I stared at her wide, childlike eyes. How could I leave my loving, erratic, harebrained mother to fend for herself? Of course she had Phil now, so the bills would probably get paid, there would be food in the refrigerator, gas in her car, and someone to call when she got lost, but still...

“I *want* to go,” I lied. I'd always been a bad liar, but I'd been saying this lie so frequently lately that it sounded almost convincing now.

from Stephenie Meyer's *Twilight*

**Why Won't My
Weird
Kids Listen?**

a 2010 talk by Graham Mitchell

Review



7% - words used

38% - tone of voice

55% - nonverbal



deaf ?



Classroom Issues

1) He corrects me.

1) He corrects me.

what he's thinking

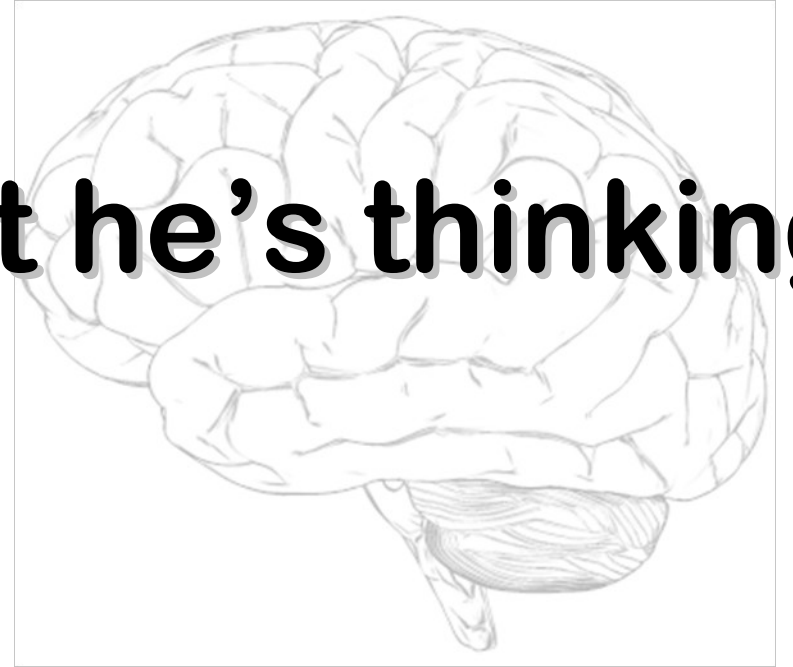

1) He corrects me.

what he's thinking

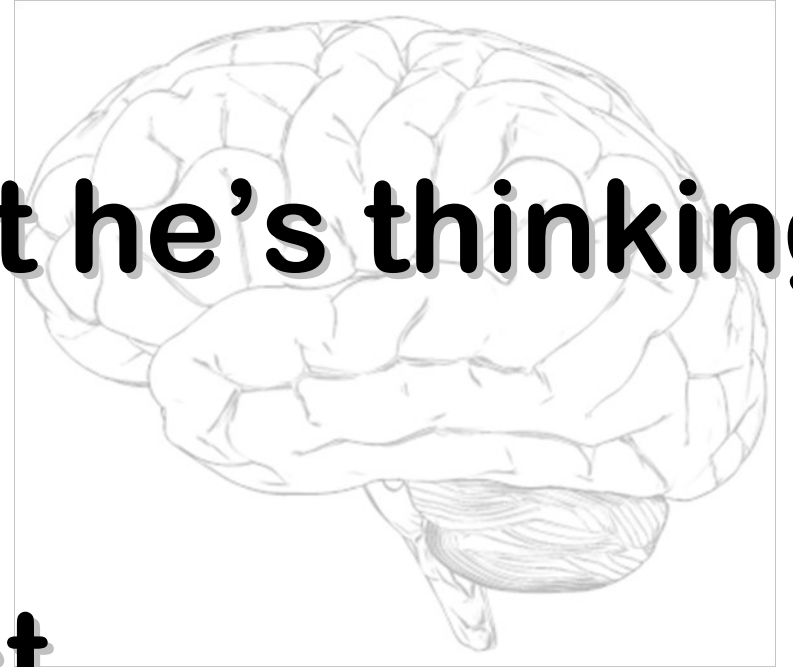

**Being incorrect
is worse
than being corrected.**

Tact Filters

(concept courtesy of Jeff Bigler from MIT)

Tact Filters

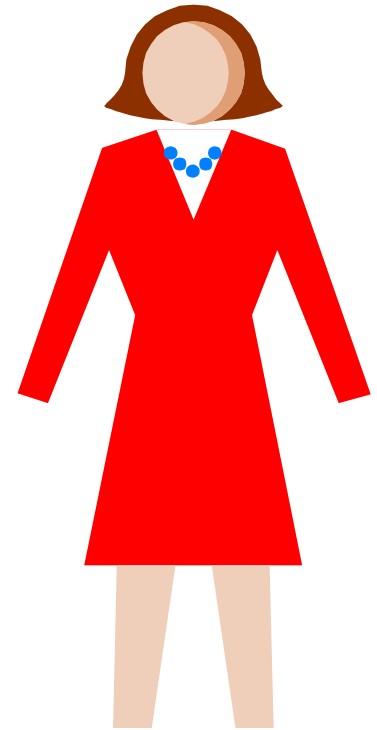
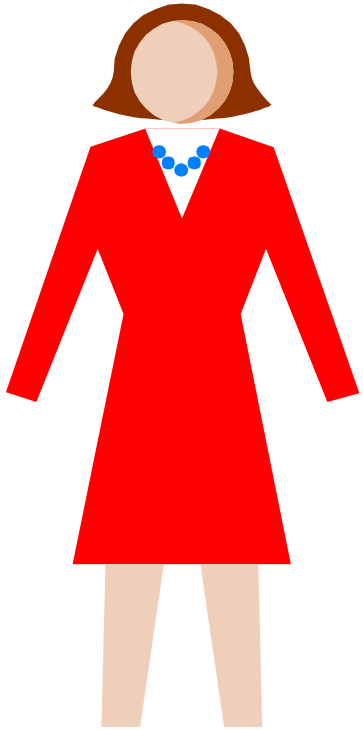

Tact Filters

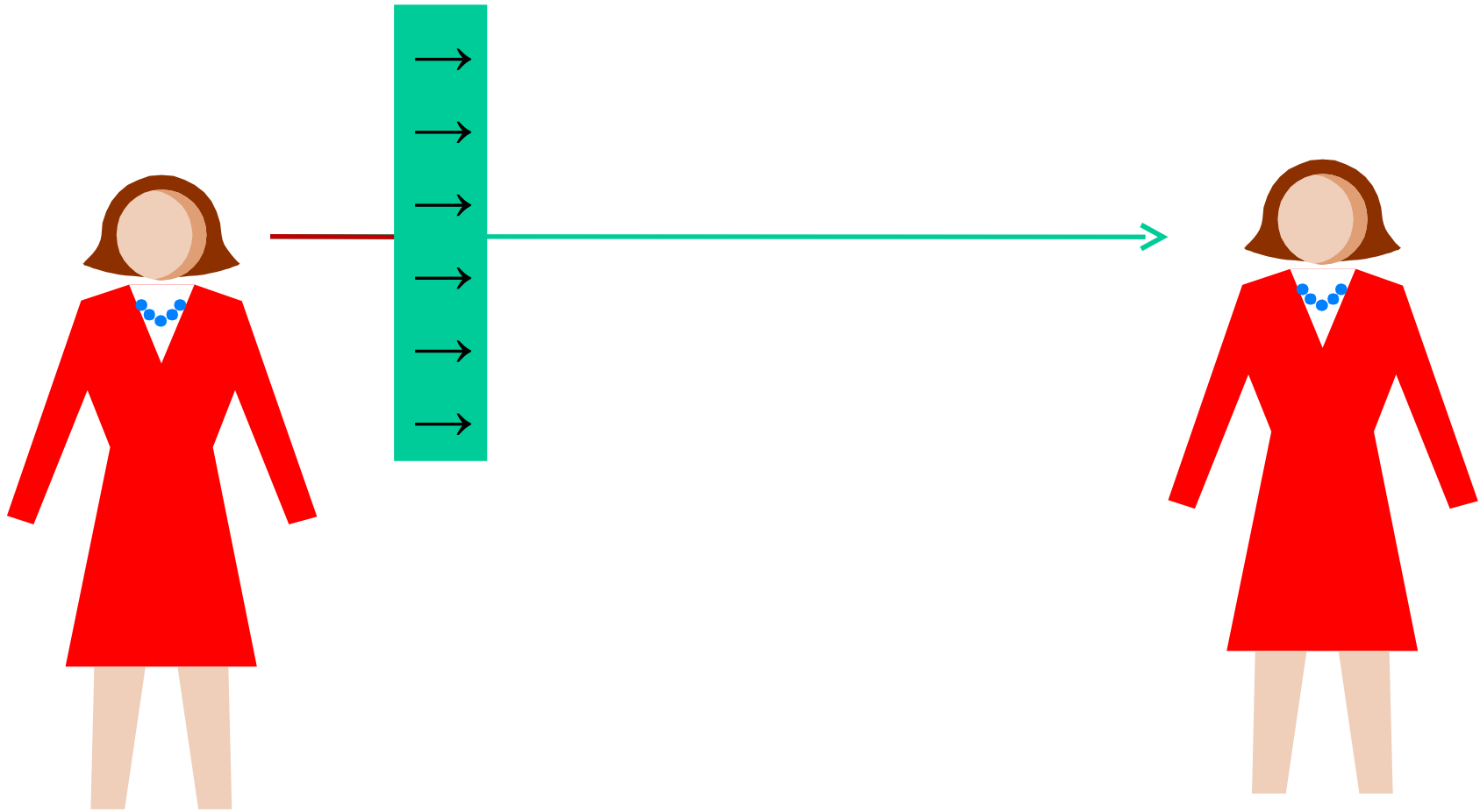

Tact Filters

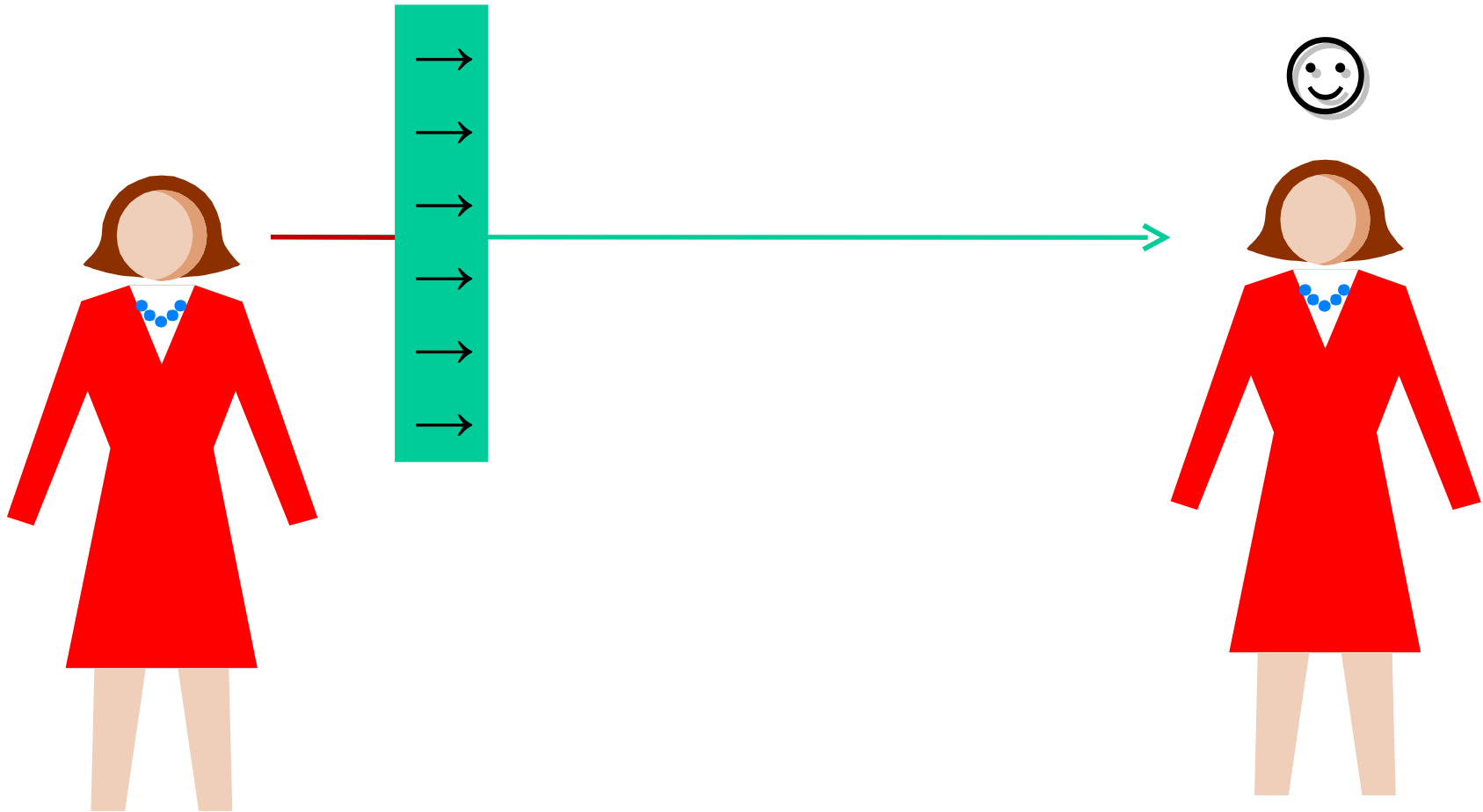

Tact Filters

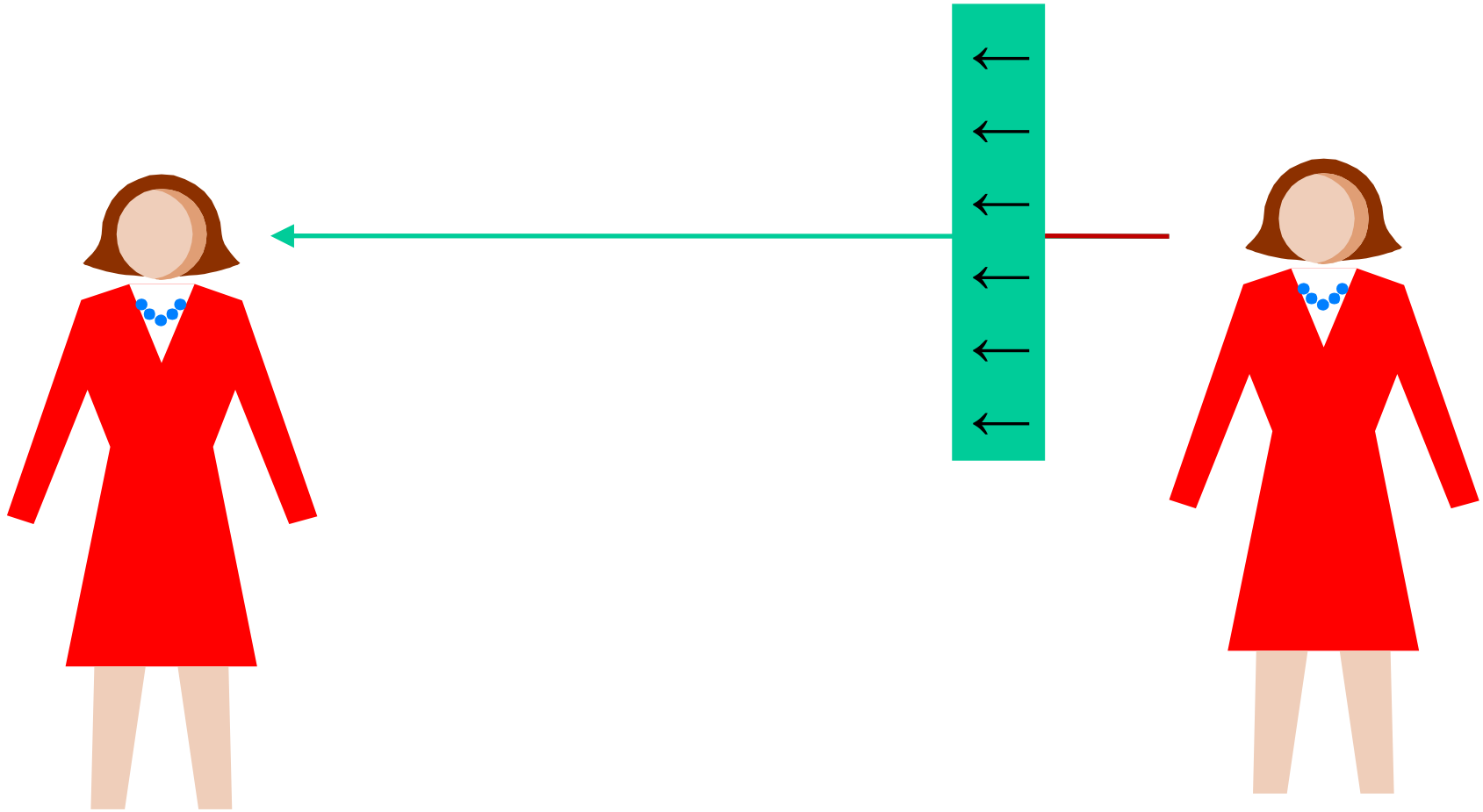

Tact Filters

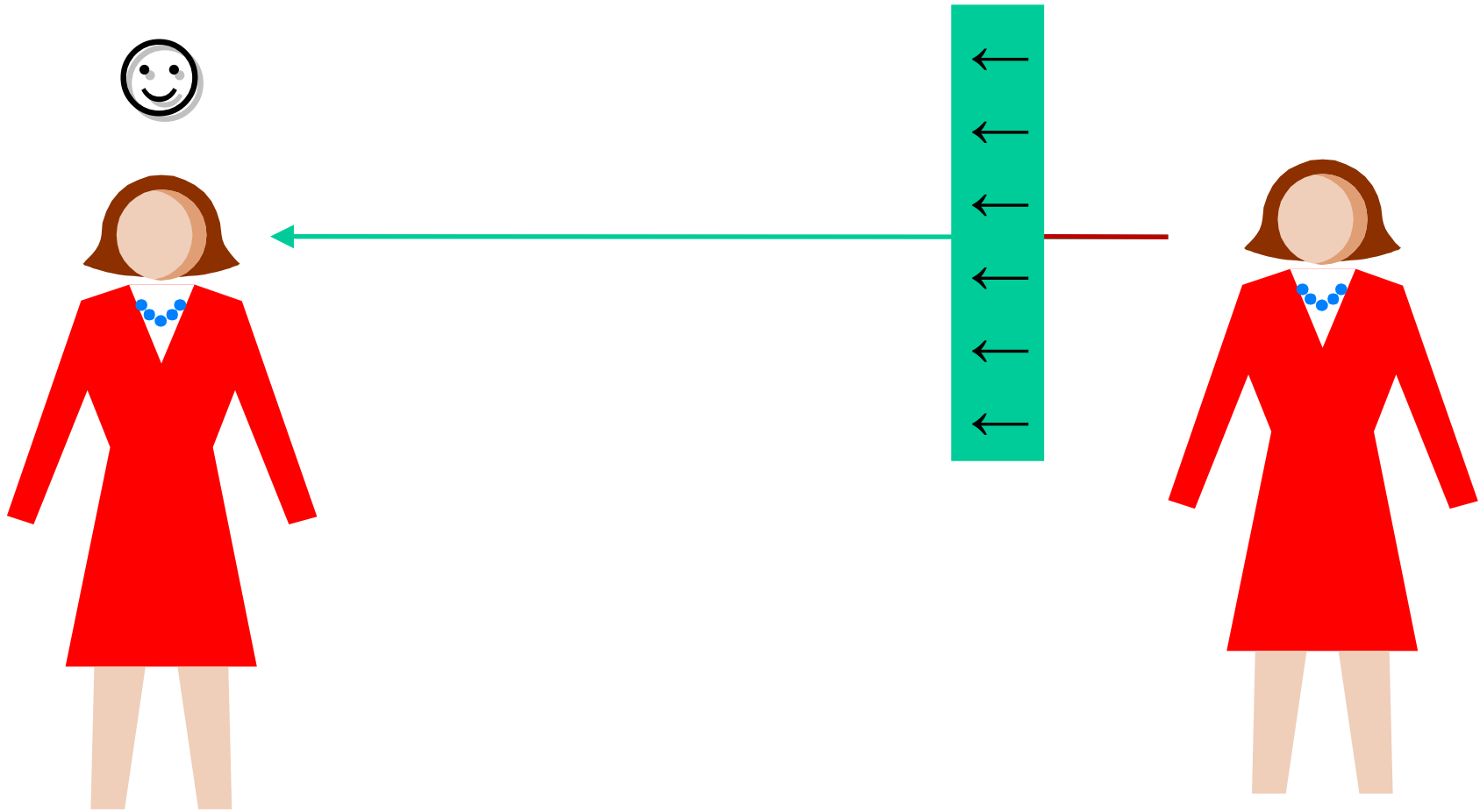

Tact Filters

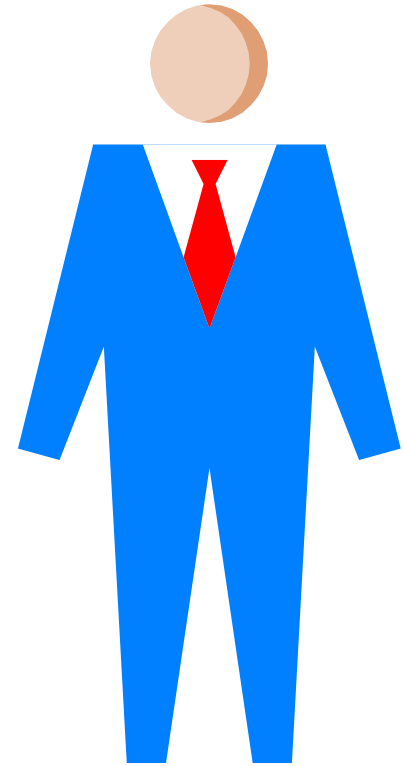
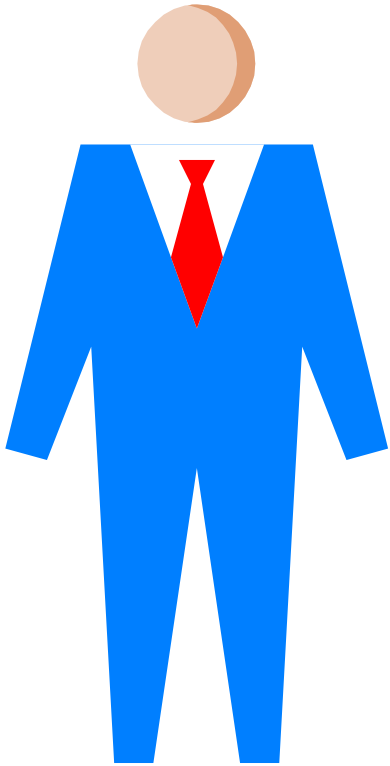

Tact Filters

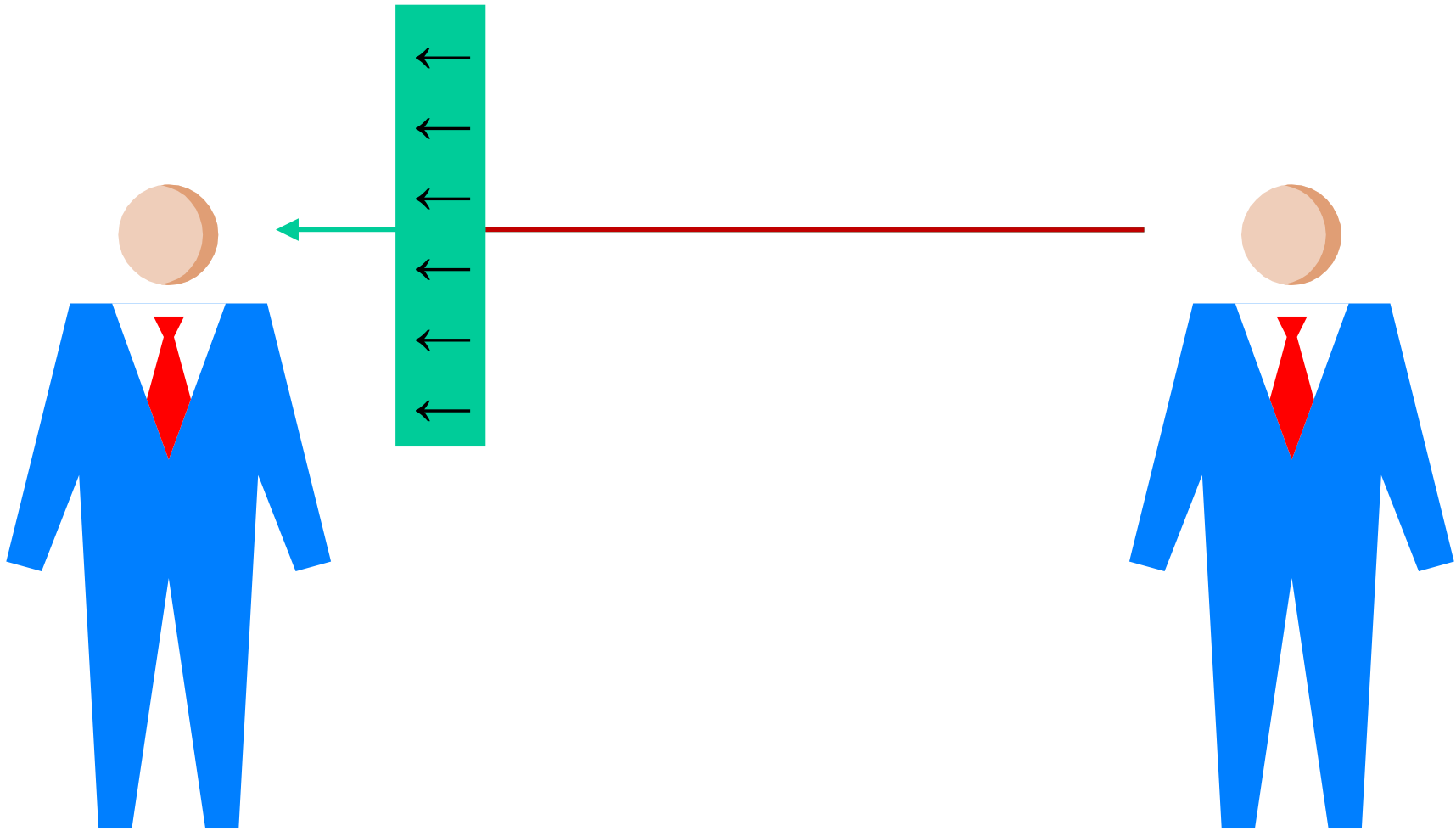

Tact Filters

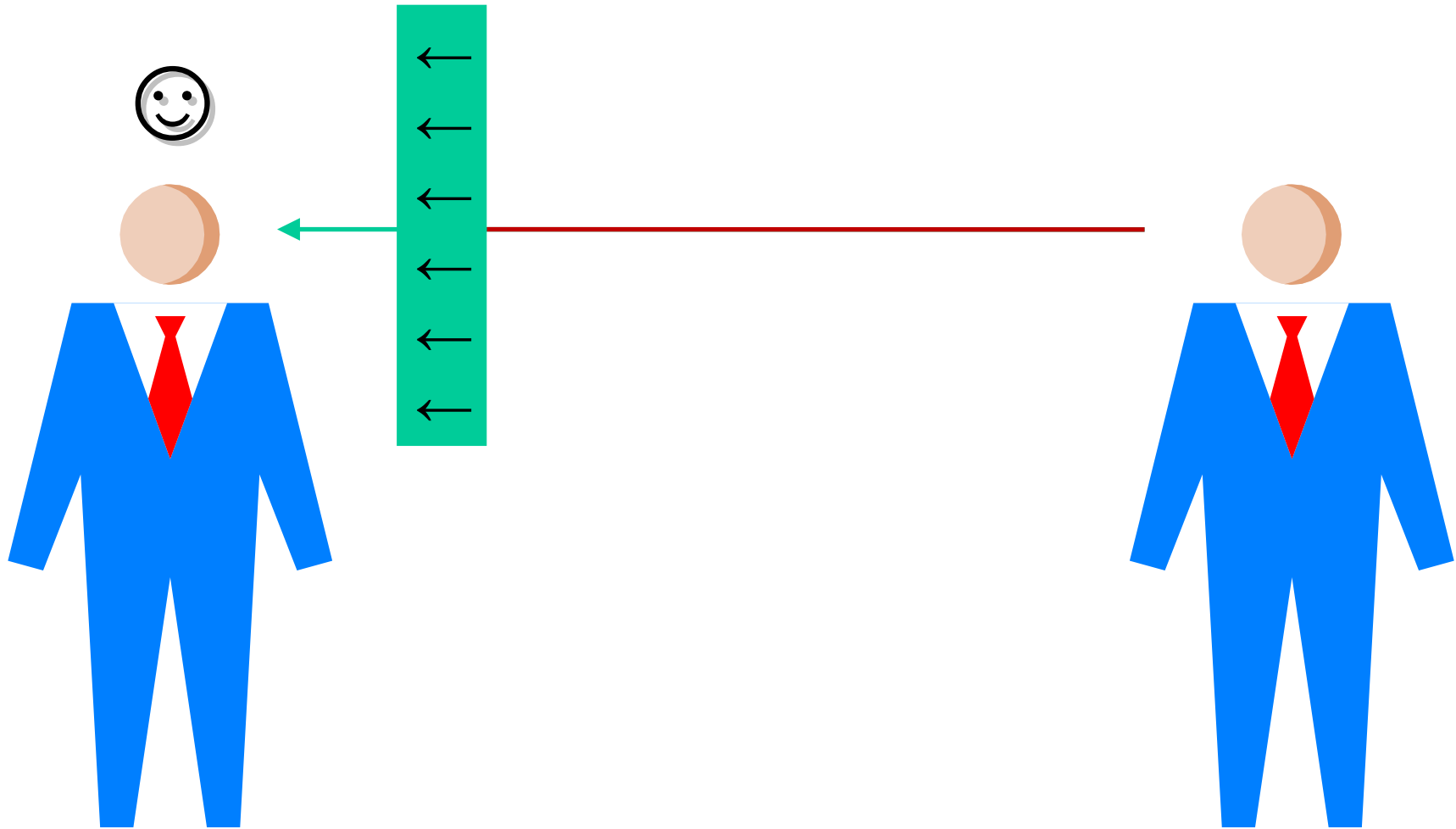

Tact Filters

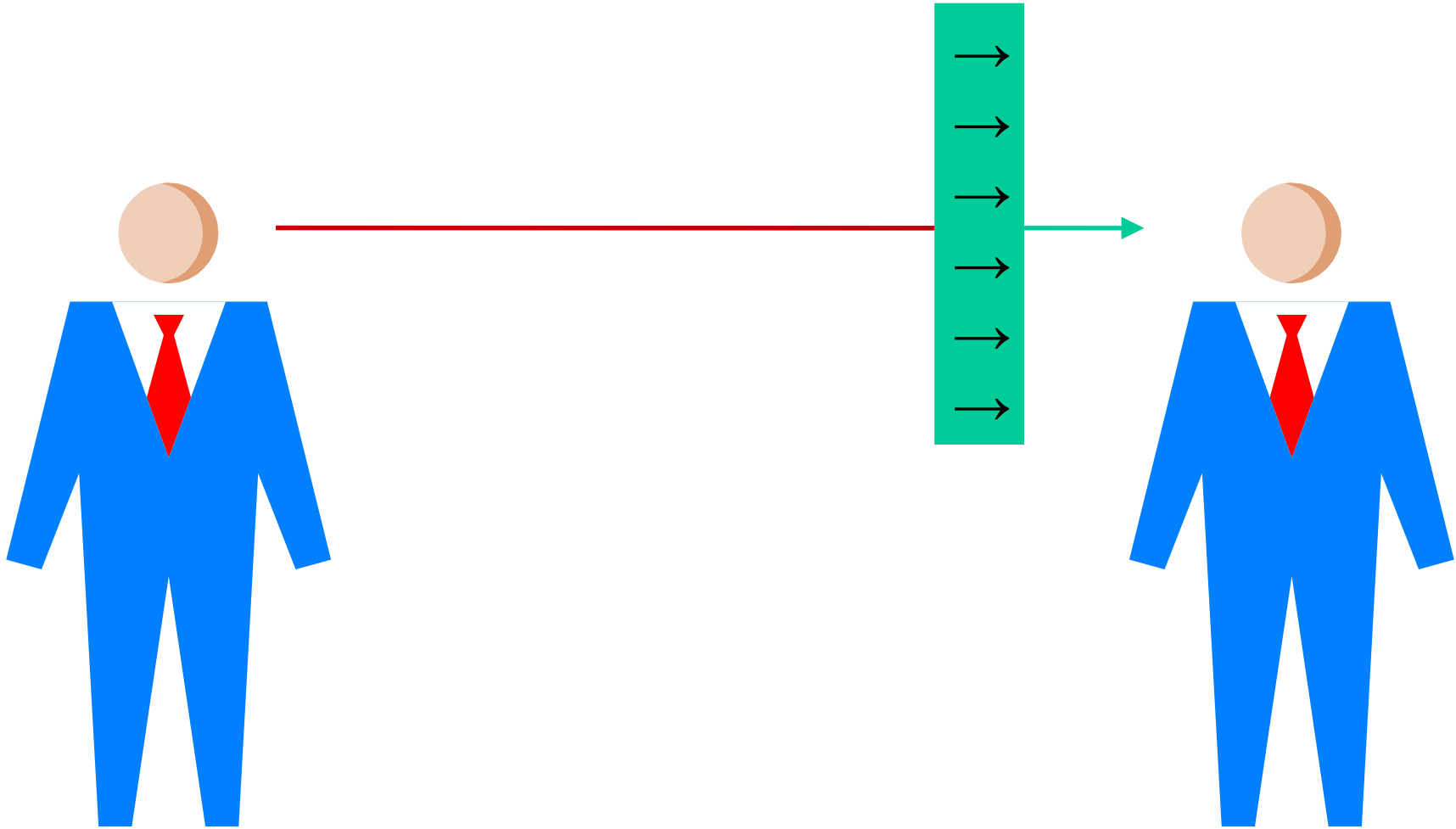

Tact Filters

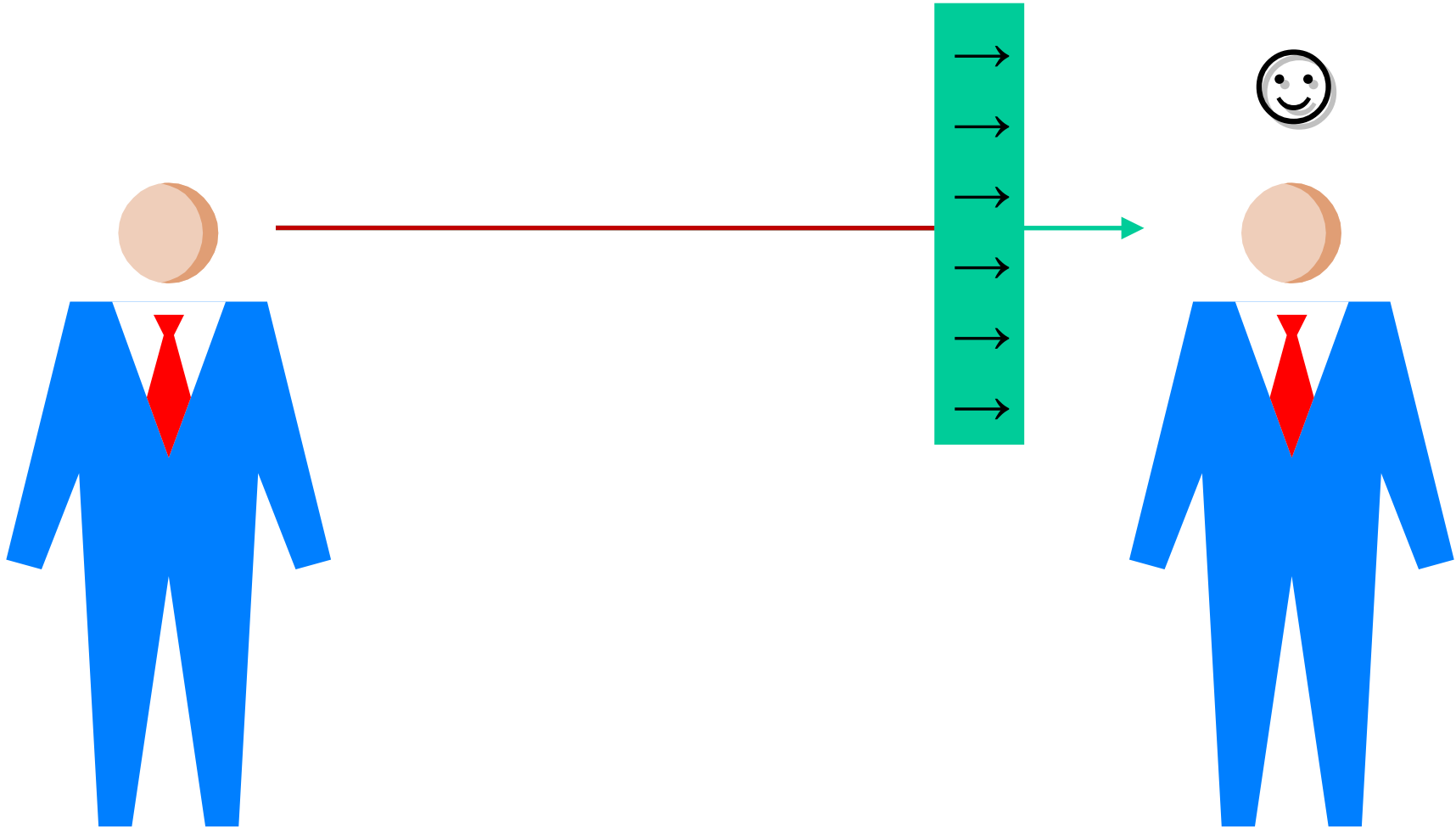

Tact Filters

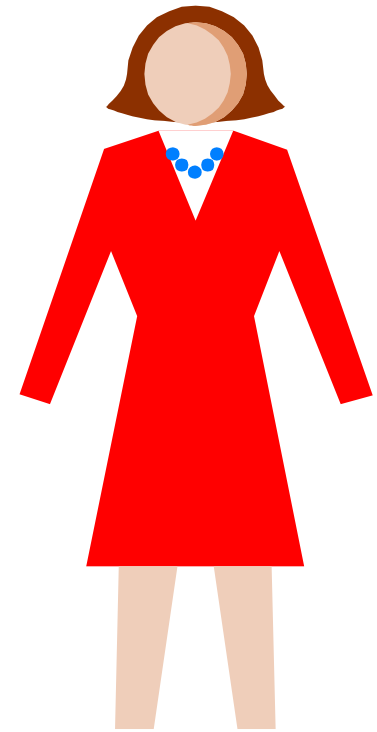
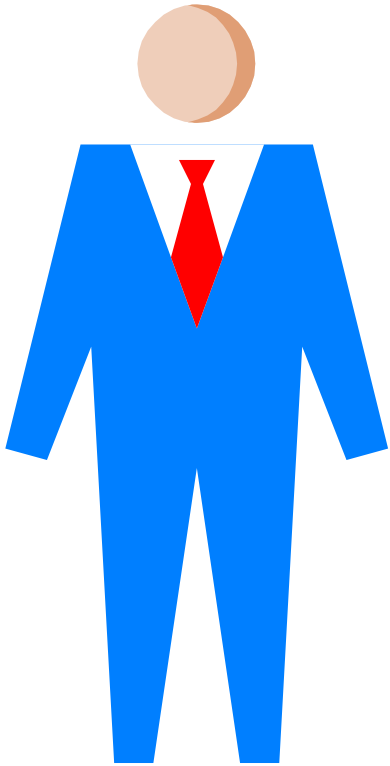

Tact Filters

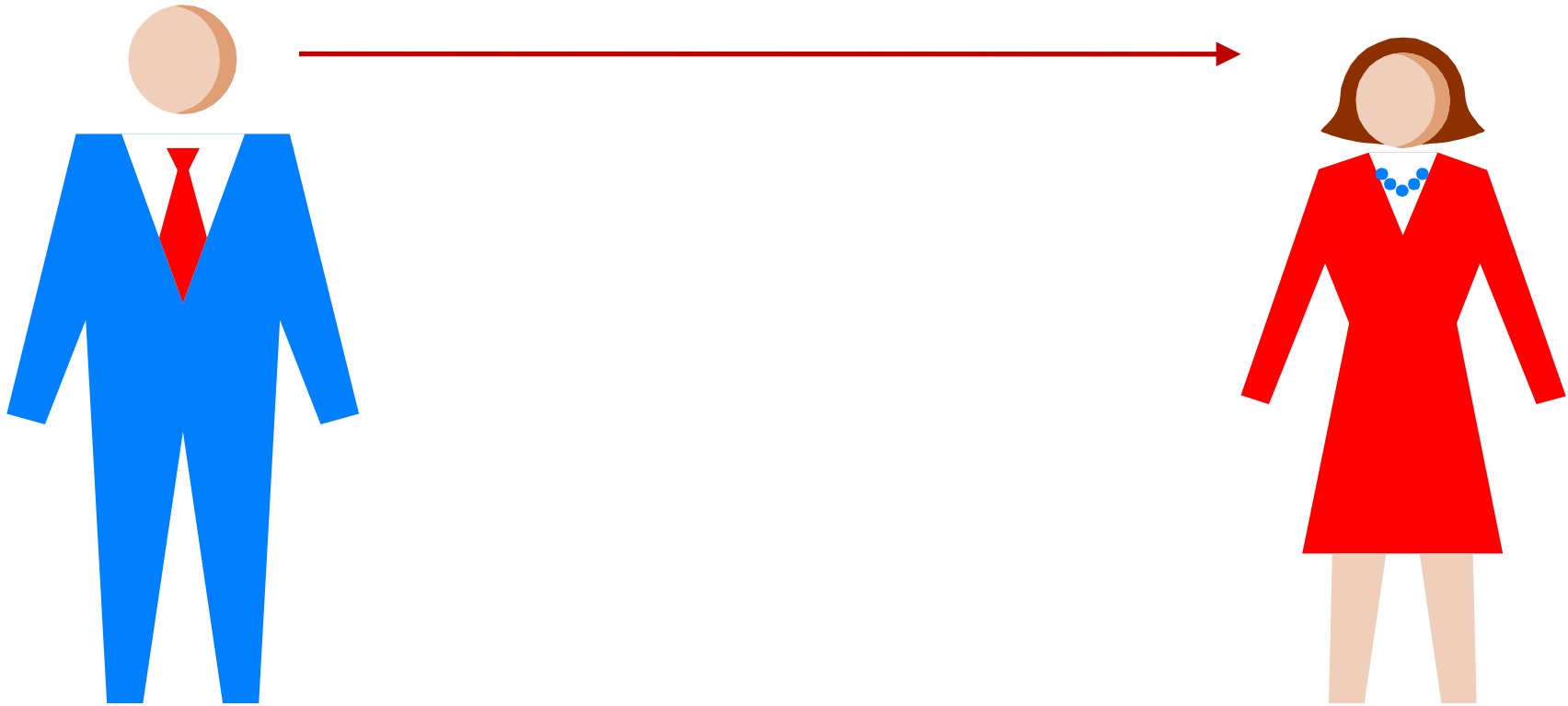

Tact Filters

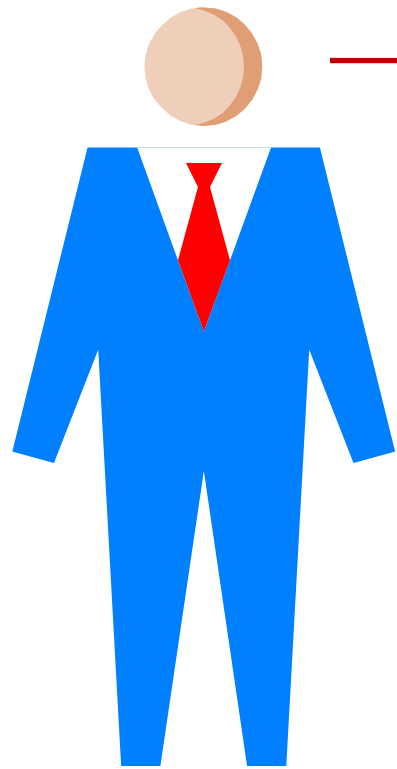

#\$@%!

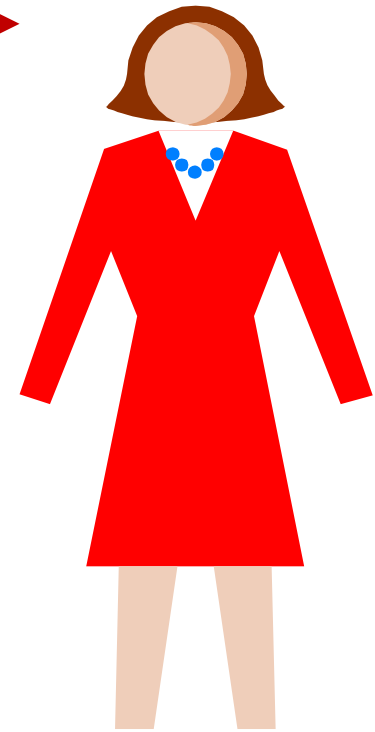

Tact Filters

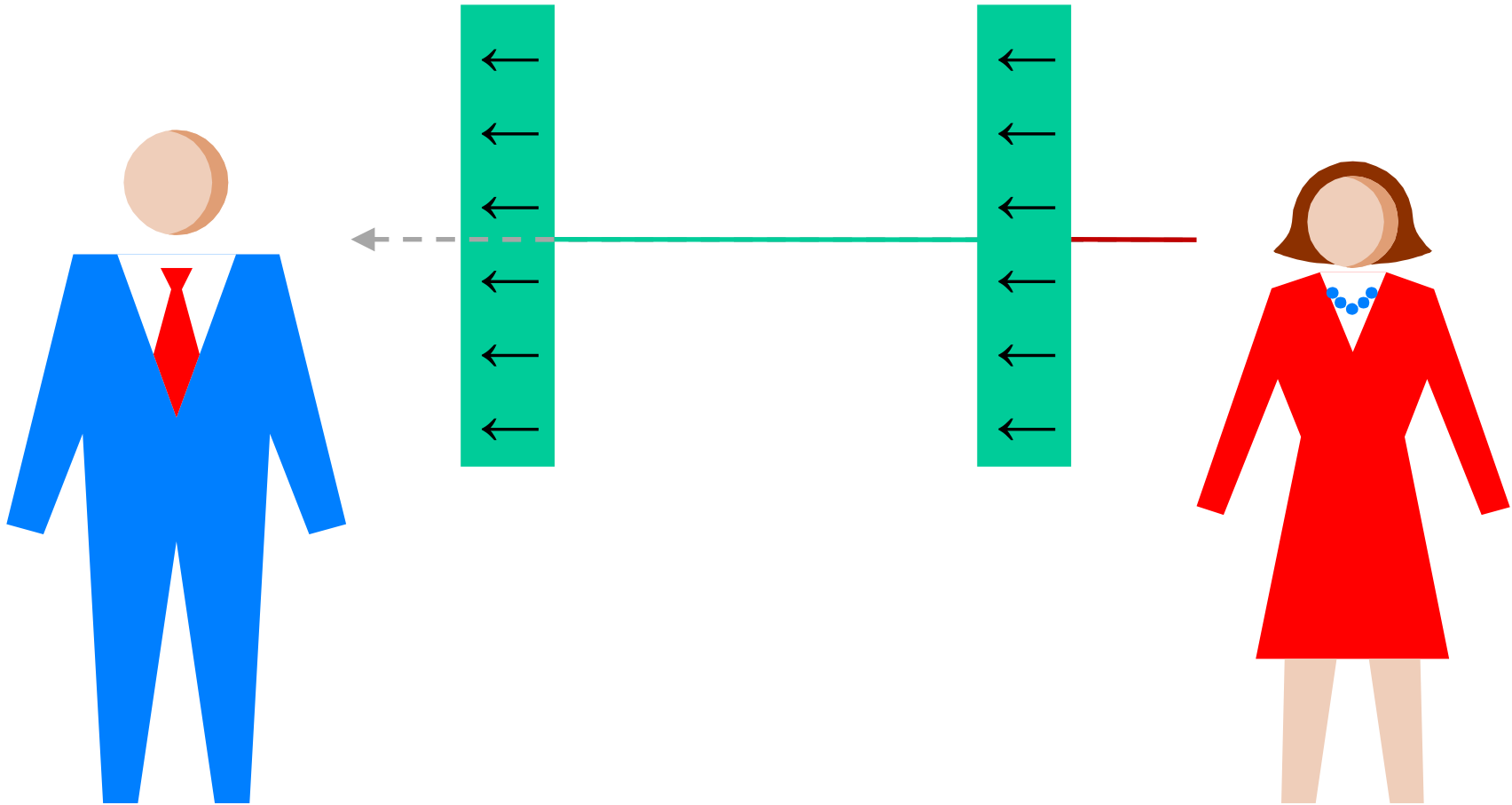

Tact Filters

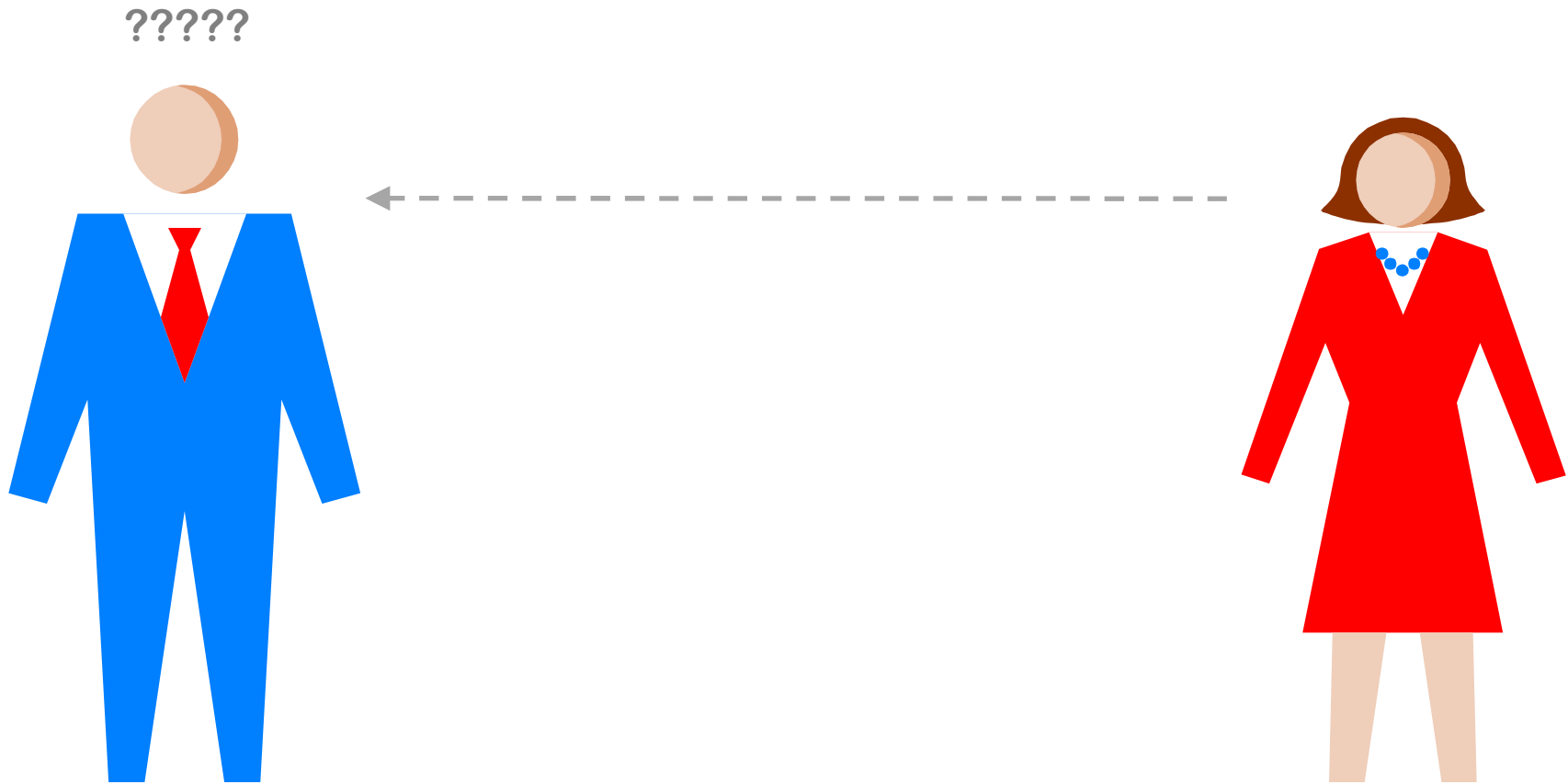

1) He corrects me.

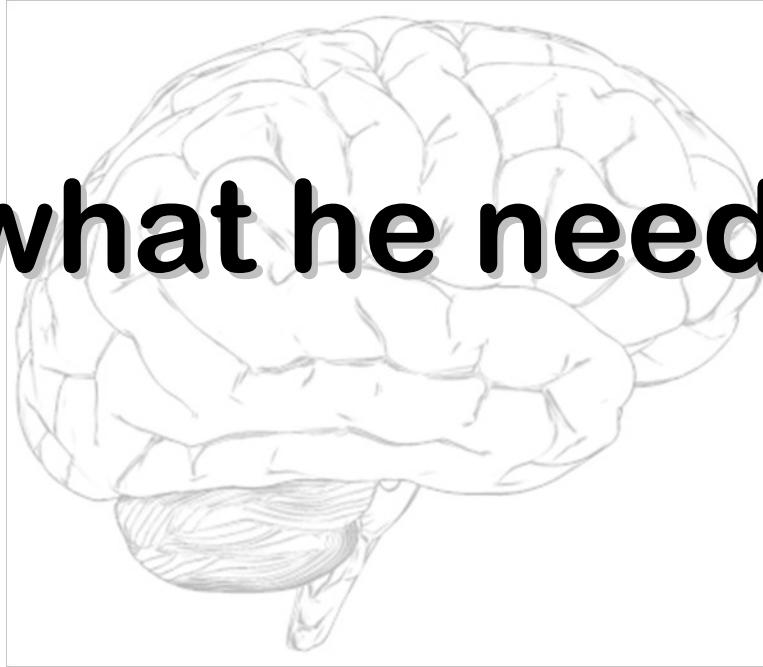

what he needs to know

1) He corrects me.

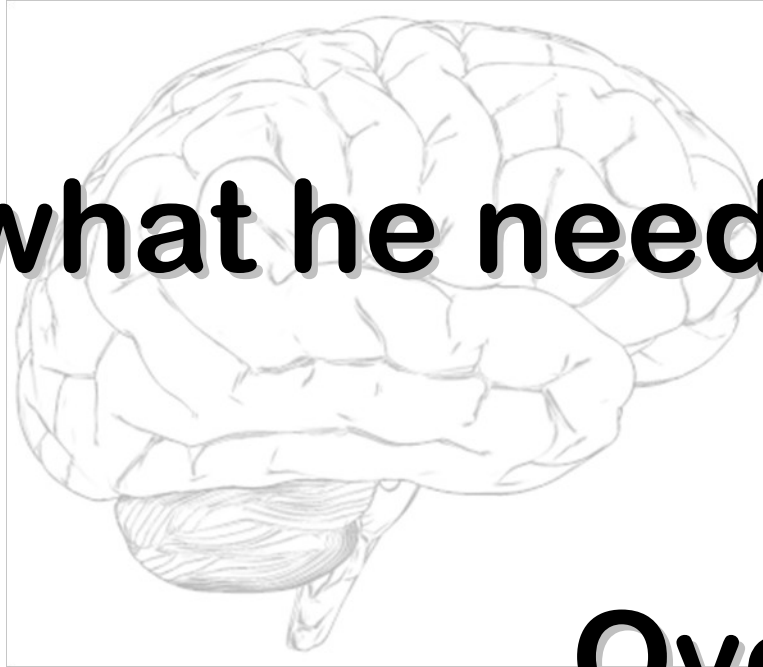

what he needs to know

**Over-simplification
is often better
than confusion.**

2) He interrupts me.

2) He interrupts me.

what he's thinking

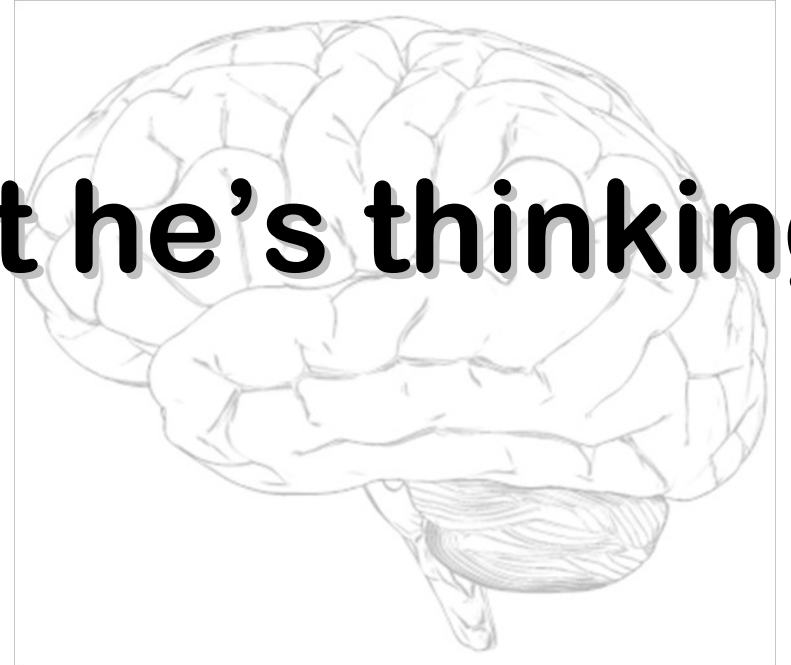

2) He interrupts me.

what he's thinking

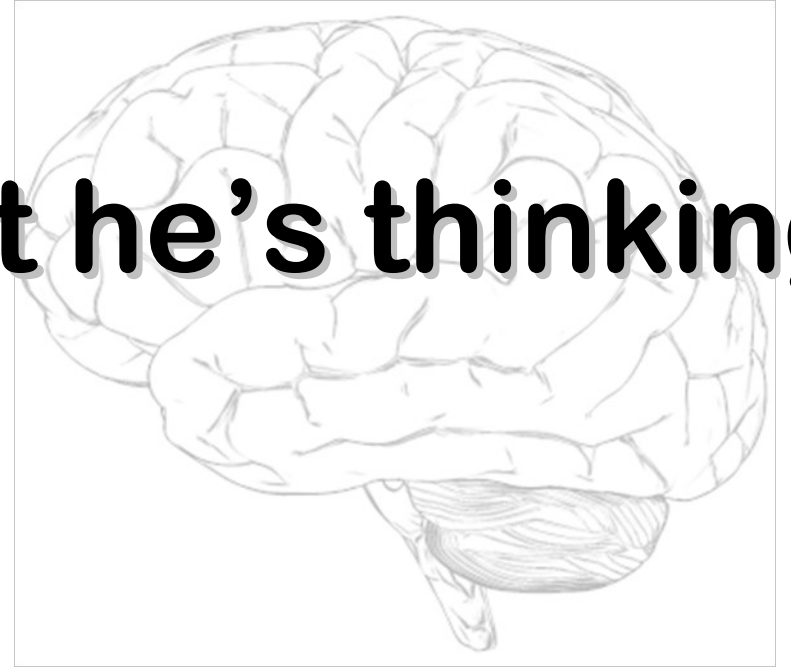

**“This is
important.”**

medial prefrontal cortex

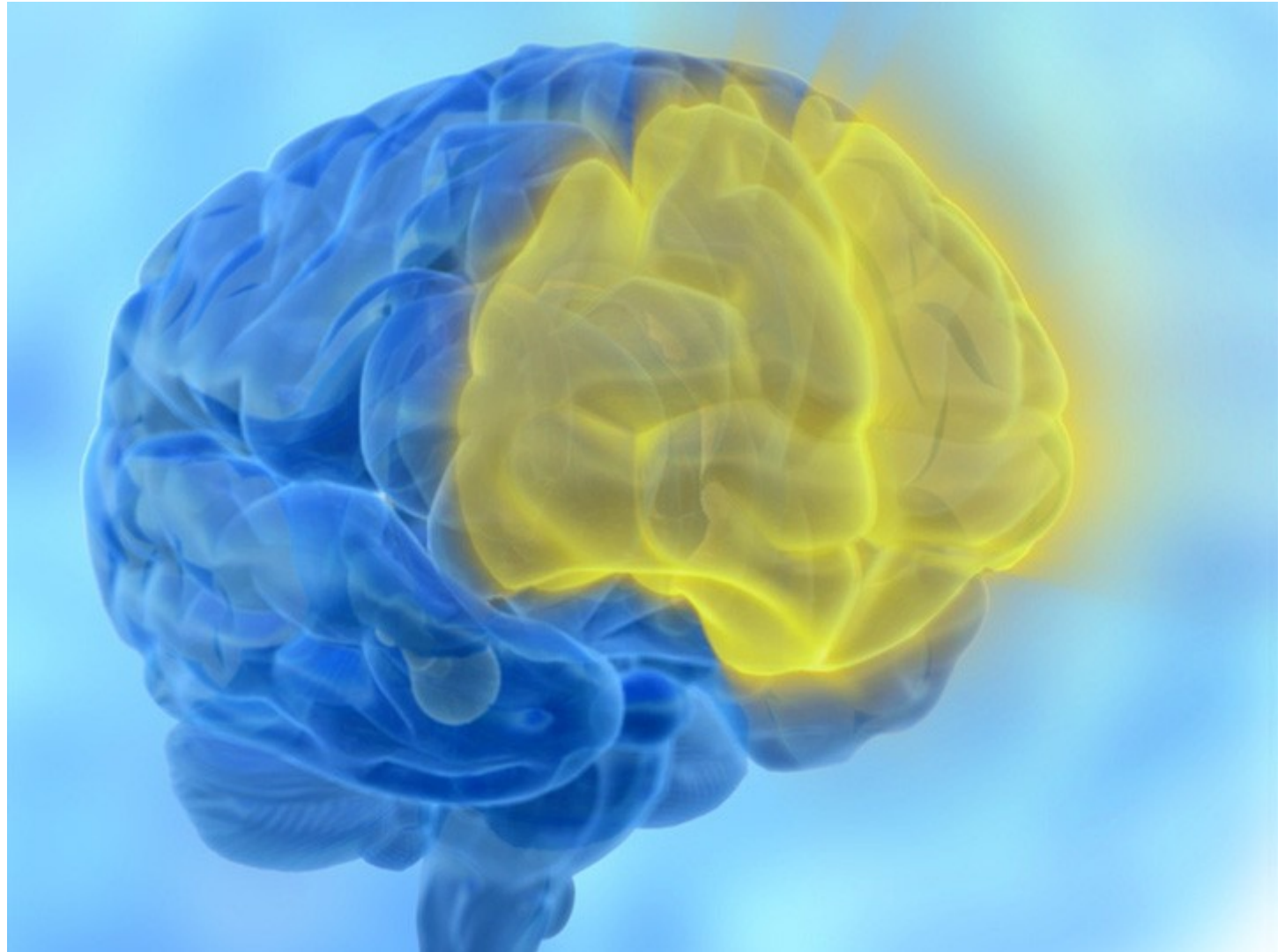

2) He interrupts me.

what he needs to know

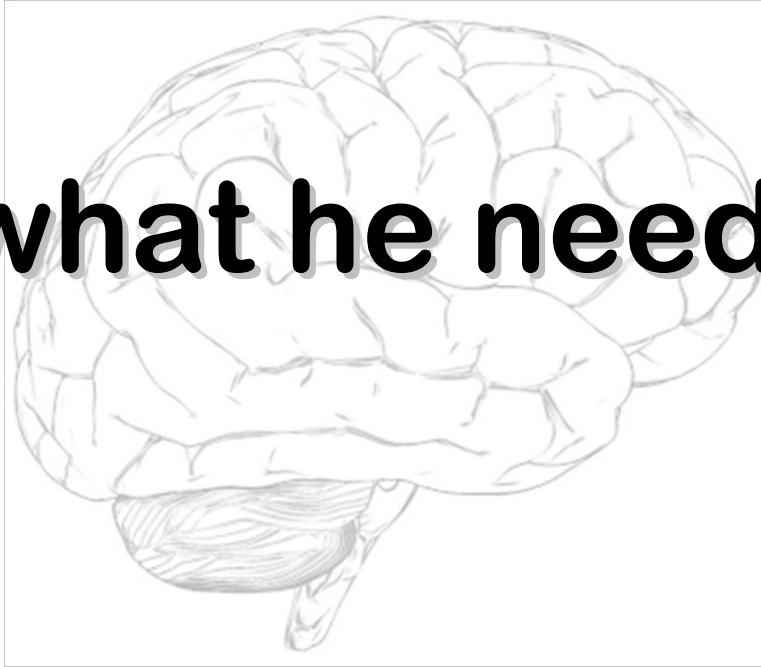

**The flow of conversation
is more important.**

3) He doesn't pay attention.

3) He doesn't pay attention.

what he's thinking

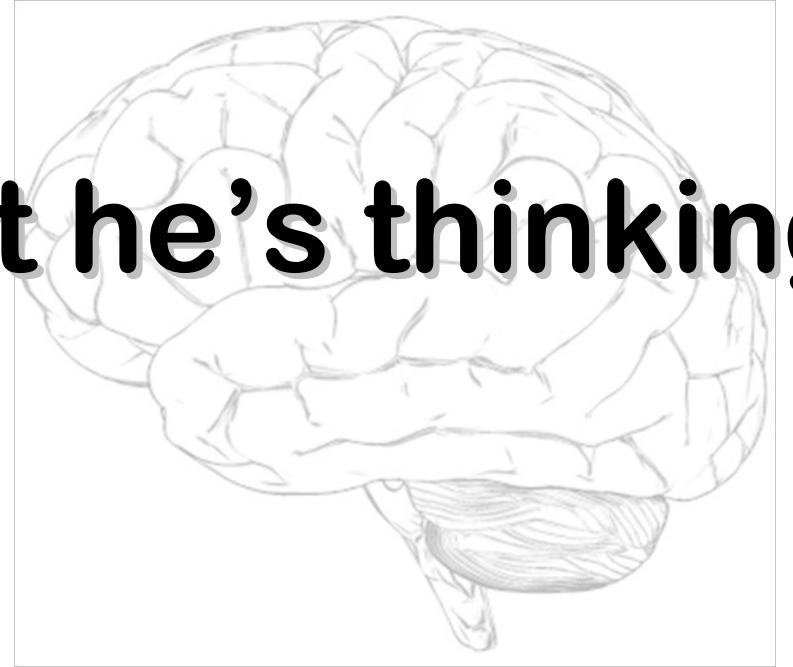

3) He doesn't pay attention.

what he's thinking

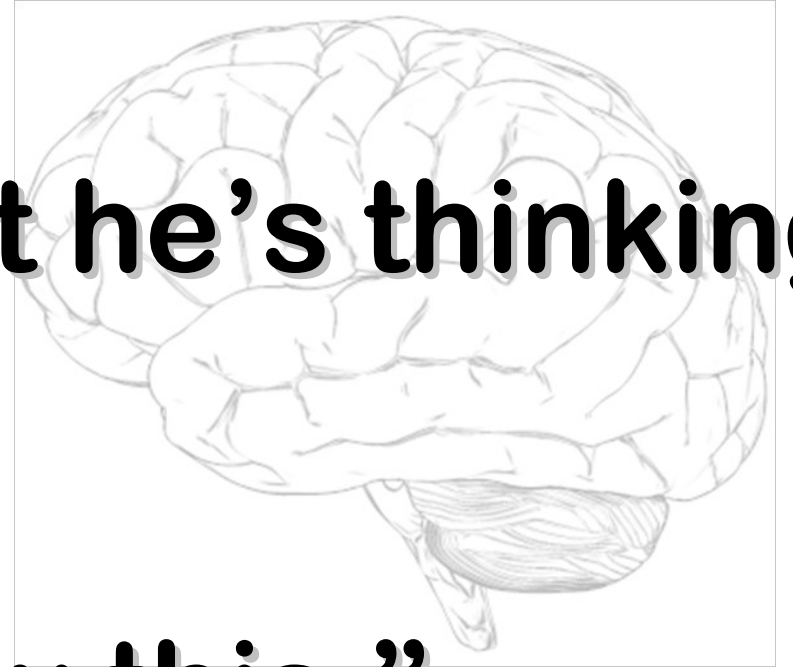

“I already know this.”

3) He doesn't pay attention.

what he's thinking

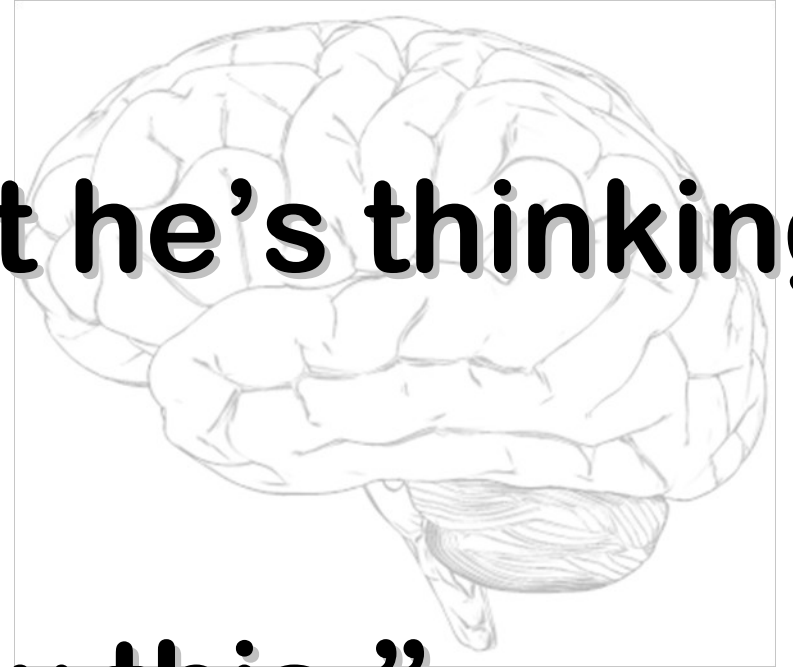

“I already know this.”

or

“This isn't worth learning.”



Google™

3) He doesn't pay attention.

what he needs to know

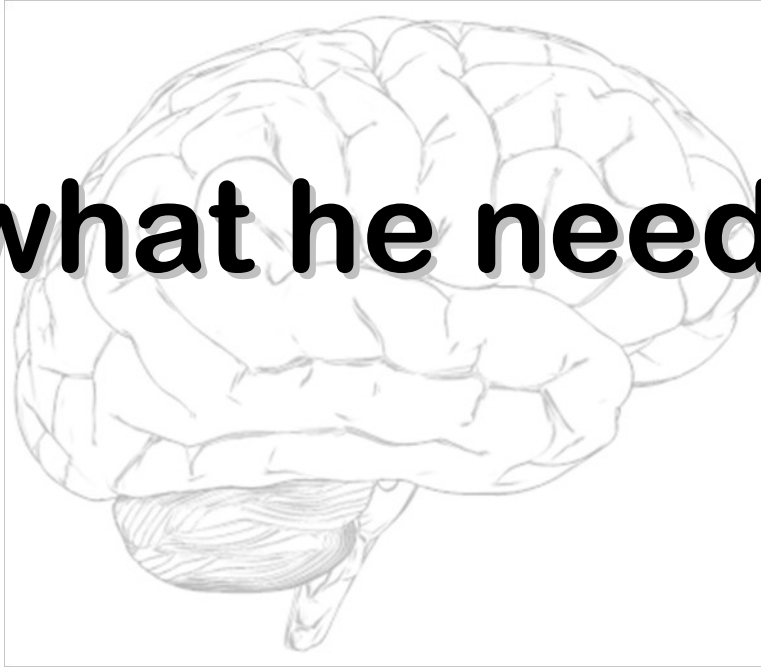

**Practice makes
perfect.**

3) He doesn't pay attention.

what **you** need to know

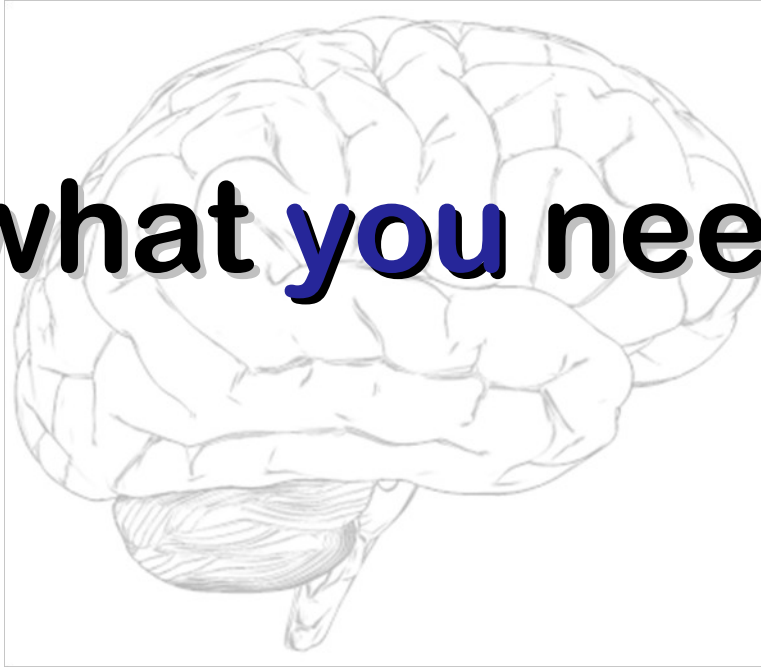

**It is okay to boast
sometimes.**

4) He won't do what I ask.

4) He won't do what I ask.

what he's thinking

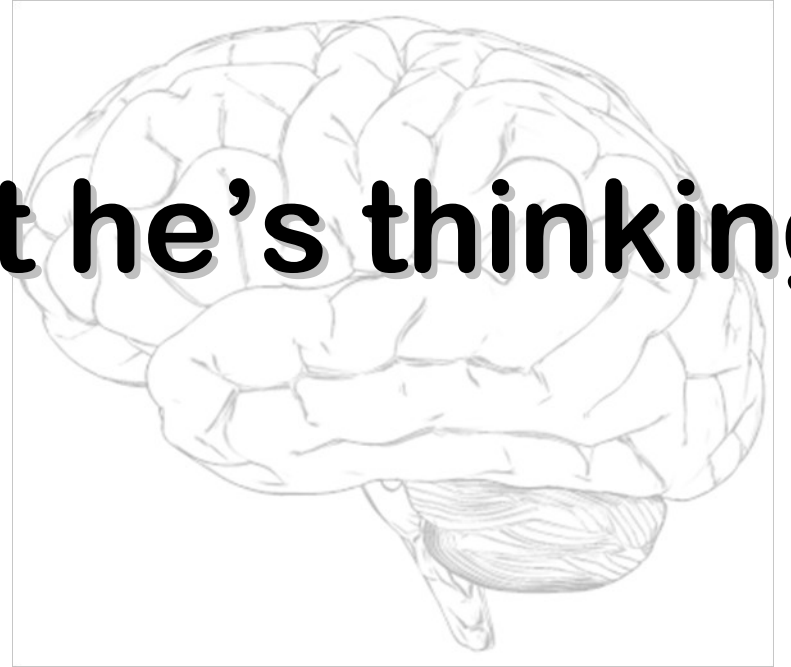

4) He won't do what I ask.

what he's thinking

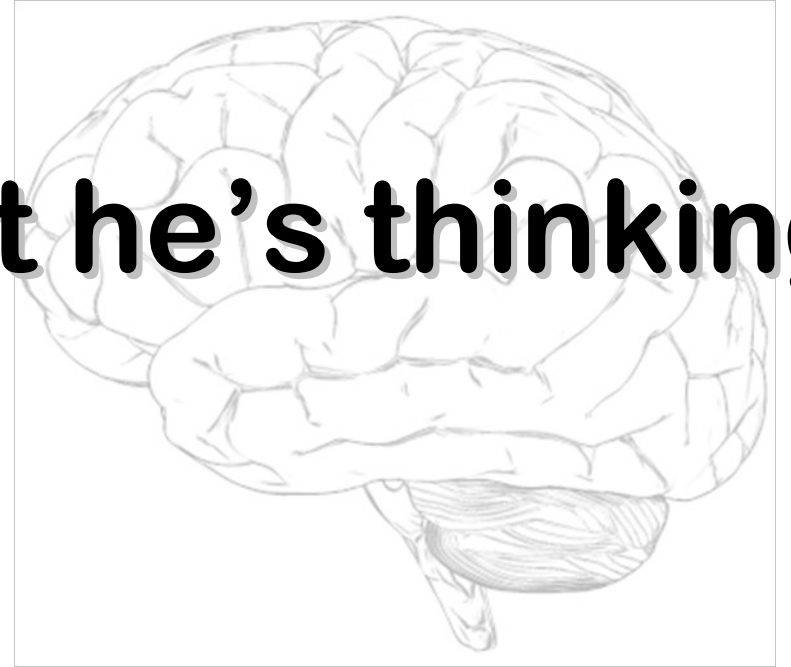

**“This isn't
worth doing.”**

4) He won't do what I ask.

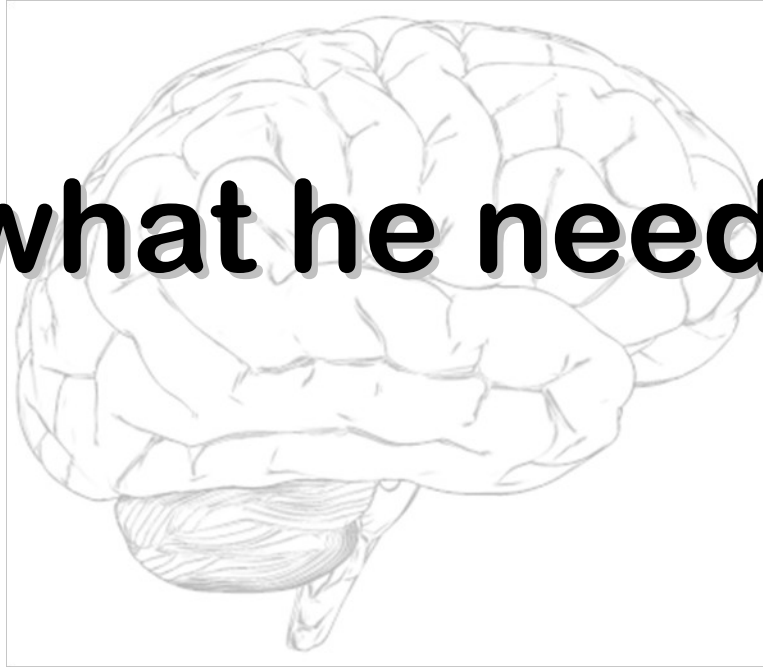

what he needs to know

**Effort is much more
rare and more valuable
than intelligence.**

4) He won't do what I ask.

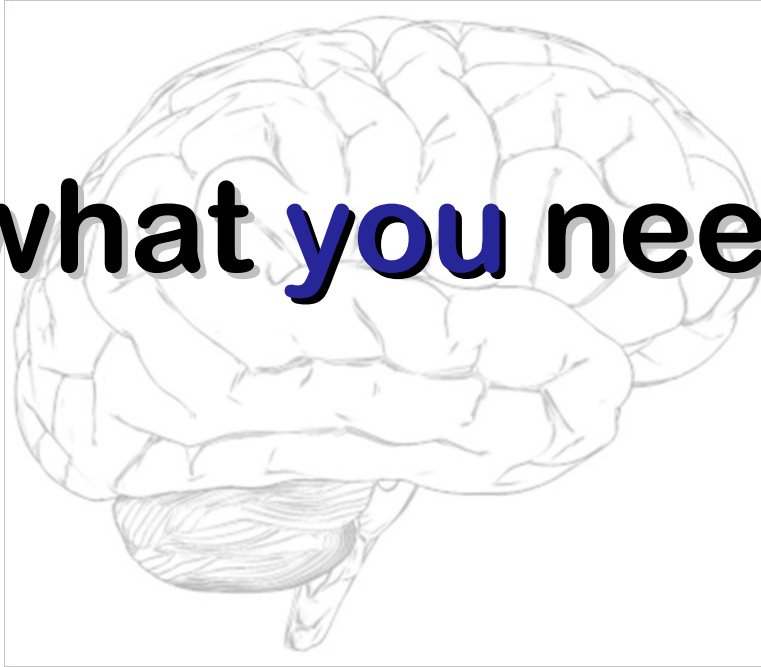

what **you need to know**

**a grade isn't
a compelling reward.**

Better than grades:

- something to show off
- proper management
- learning interesting things
- solving problems
- avoiding inefficiency
- building something that matters

Better than grades:

- something to show off
- proper management
- learning interesting things
- solving problems
- avoiding inefficiency
- building something that matters

Better than grades:

- something to show off
- proper management
- learning interesting things
- solving problems
- avoiding inefficiency
- building something that matters

Better than grades:

- something to show off
- proper management
- learning interesting things
- solving problems
- avoiding inefficiency
- building something that matters

Better than grades:

- something to show off
- proper management
- learning interesting things
- solving problems
- avoiding inefficiency
- building something that matters

Better than grades:

- something to show off
- proper management
- learning interesting things
- solving problems
- avoiding inefficiency
- building something that matters

5) He annoys others.

5) He annoys *me*.

5) He annoys others.

5) He annoys others.

what he's thinking

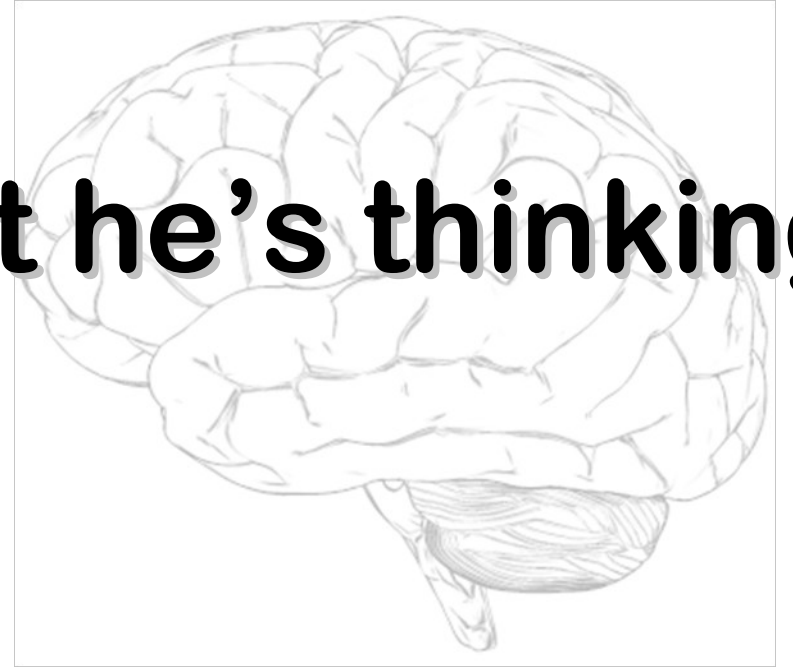

5) He annoys others.

what he's thinking

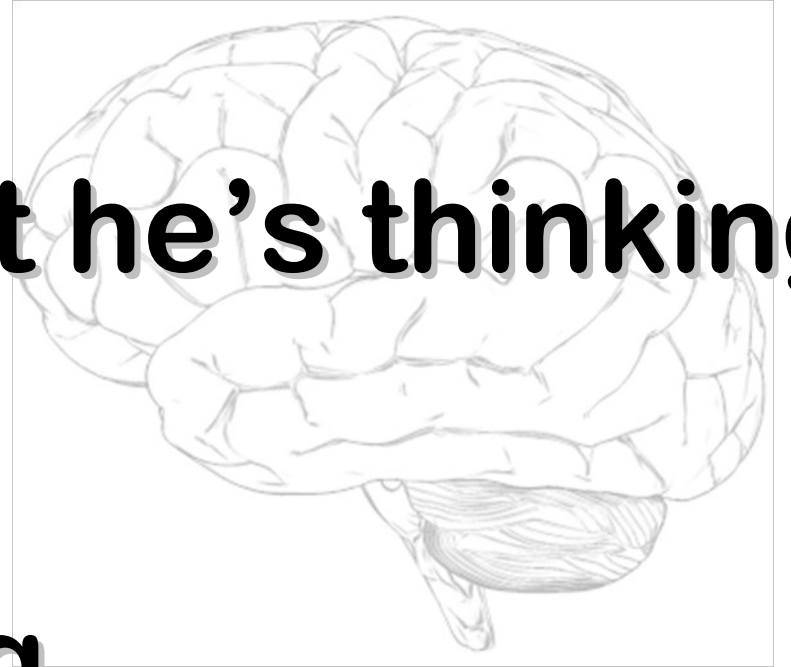

**“I’m just talking
to my friend.”**

5) He annoys others.

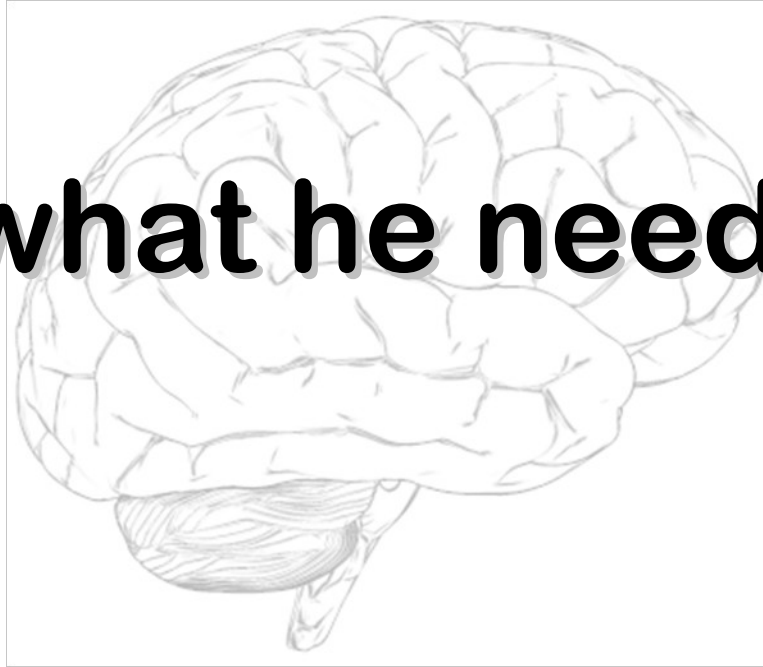

what he needs to know

**Friendship needs
to be symmetric.**

Stages of typical relationships:

0. unknown
1. strangers
2. acquaintances
3. friends
4. dating
5. boyfriend/girlfriend
6. engaged
7. married

5) He annoys others.

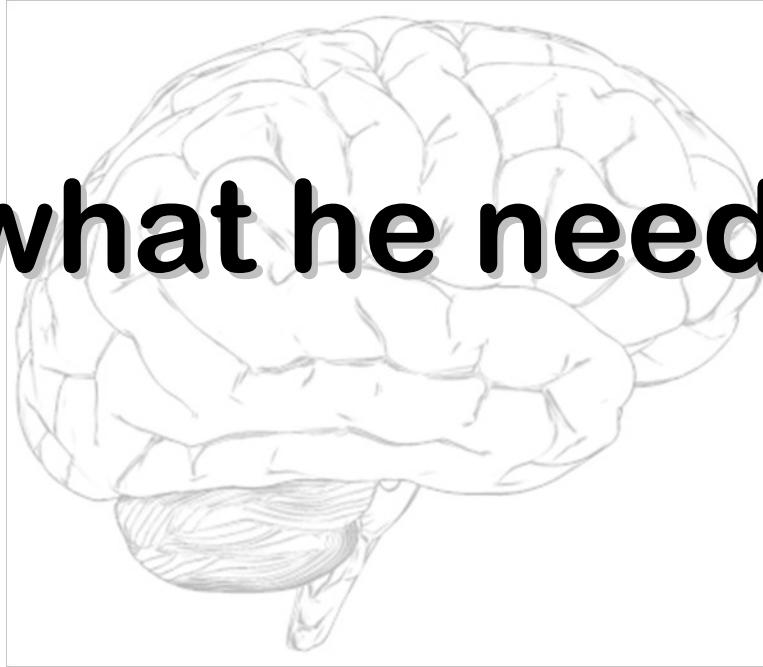

what he needs to know

**Friendship may take
some searching.**



WINTERFEST

TOURNAMENT

Questions?

Don't **Be** **Creepy**

<http://dontbecreepy.com/>

Don't Be Creepy

facebook®